

Technical Information

C80 W



AQUAFIX BELGIUM BVBA
Tel. 013 66 83 03, WWW.AQUAFIX.BE



AQUAFIX MILIEU B.V.
Tel. 0297 26 29 29, WWW.AQUAFIX.NL

Operating data	
Flow	0 m ³ /h
Head	0 m
Shaft power P2	
Pump efficiency	s %
Required pump NPSH	
Pumpe type	Single head pump
No. of pumps	1
Fluid	Water, clean

Pump	
Pump Code	C80 W
Impeller	Multi vane impeller
Impeller size	0 mm
Solid size	1 mm
Discharge port	R 3/4" AG
Suction port	s

Motor data	
Rated voltage	230 V
Frequency	50 Hz
Rated power P2	0.05 kW
Rated speed	2900 rpm
Number of poles	2
Efficiency	55 %
Rated current	0.8 A
Degree of protection	IP 68

Materials	
Suction strainer	Wear resistant synthetic material
Motor housing	Stainless steel
Impeller	Glass-fibre, reinforced synthetic
Motor casing	Wear resistant synthetic material
Motor shaft	Stainless steel
Bolts	Stainless steel
Elastomeres	Nitrile Rubber
Lower Bearing	Deep Groove Ball Bearing
Upper Bearing	Deep Groove Ball Bearing

Testnorm: ISO9906 Sect. 4.4.2

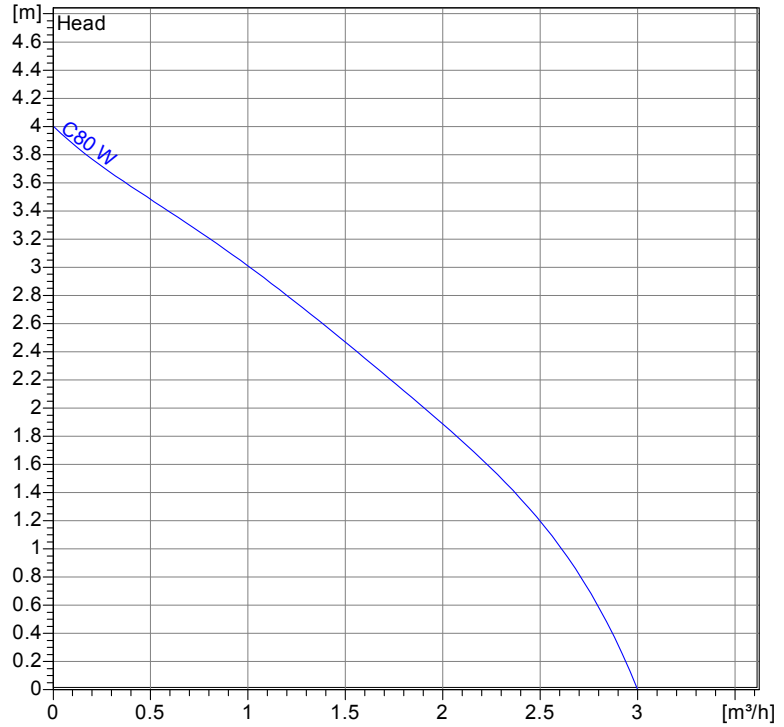

Wet well installation
Dimensions in mm, le

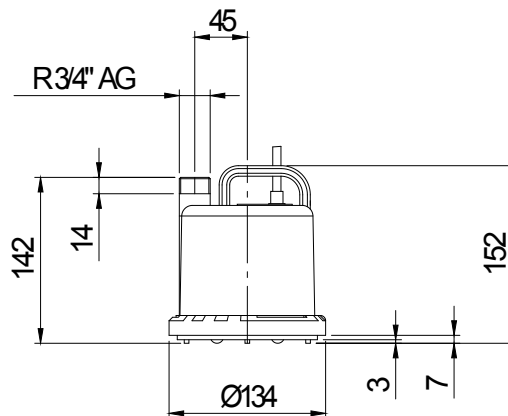

Table Dimensions (mm)

Project	Project no.:	Created by:	Page: 1
---------	--------------	-------------	------------

Performance Curve

C80 W



AQUAFIX BELGIUM BVBA
Tel. 013 66 83 03, WWW.AQUAFIX.BE



AQUAFIX MILIEU B.V.
Tel. 0297 26 29 29, WWW.AQUAFIX.NL

Impeller						
Impeller type: Multi vane impeller	Solid size 1 mm	Ø:	Max. Ø: 0 mm	Min. Ø: 0 mm	Sel. Ø: 0 mm	

Operating data					
Speed: 2900 rpm	Frequency: 50 Hz	Duty point: Q = 0 m³/h	H = 0 m	Shaft power P2:	Discharge port: R ¼" AG

Power data referred to:
Water, clean [100%] ; 20°C; 998.3kg/m³; 1.005mm²/s

Testnorm: ISO9906 Sect. 4.4.2

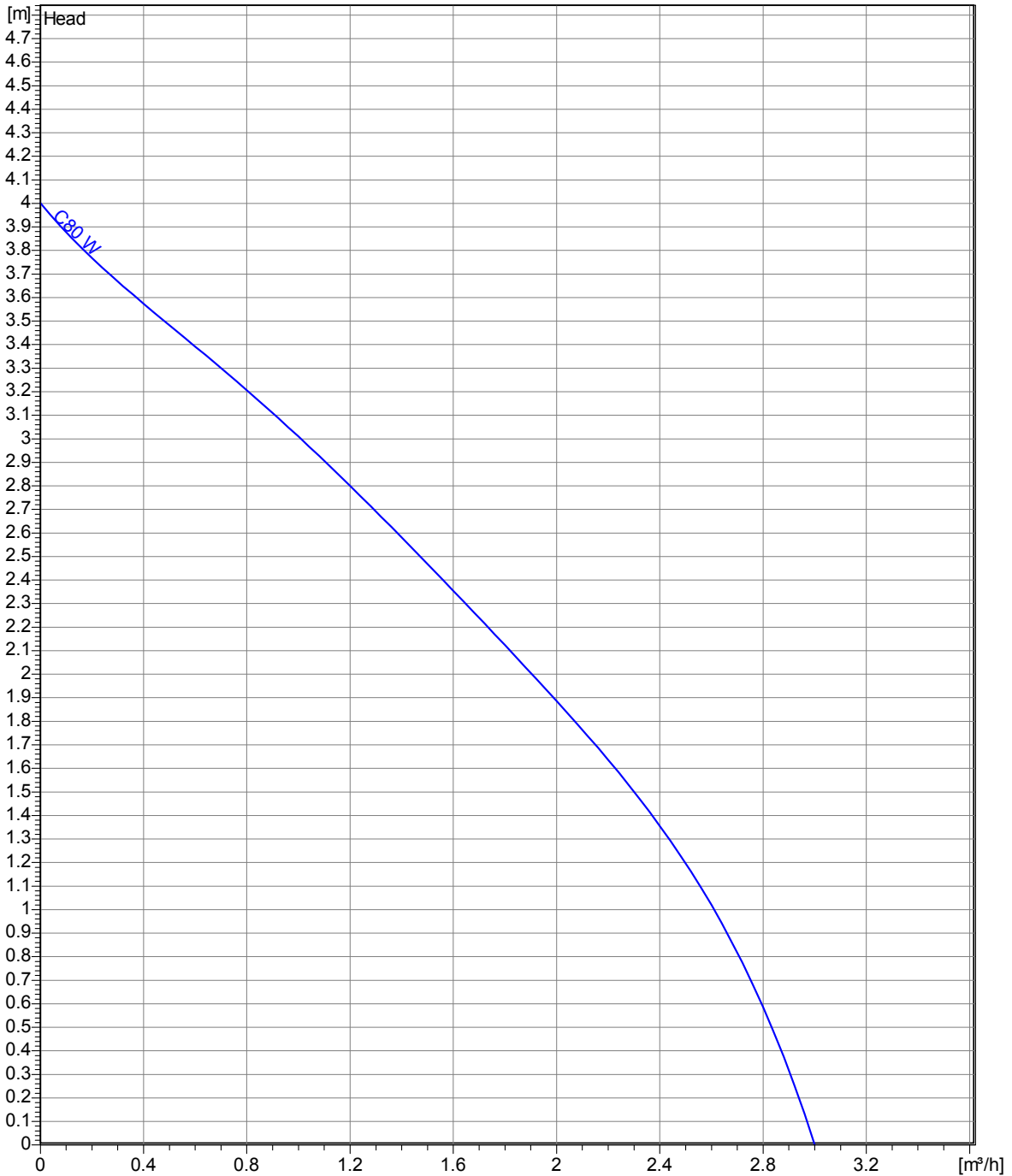

2.3.7 - 14/03/2012 (Build 345)

Project	Project no.:	Created by:	Page: 2
---------	--------------	-------------	------------

Dimensions

C80 W



AQUAFIX BELGIUM BVBA
Tel. 013 66 83 03, WWW.AQUAFIX.BE



AQUAFIX MILIEU B.V.
Tel. 0297 26 29 29, WWW.AQUAFIX.NL

Wet well installation
Dimensions in mm, le

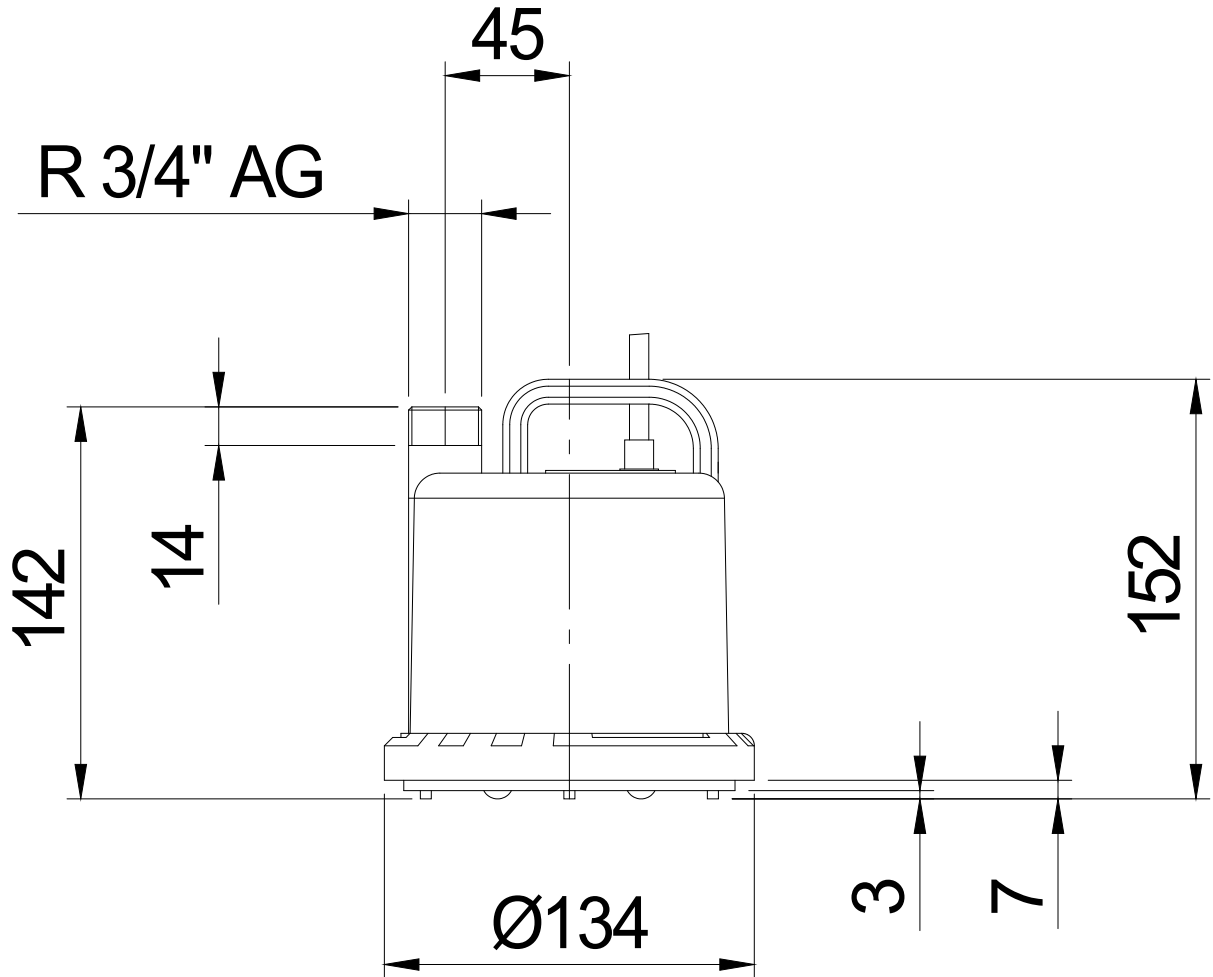

Table Dimensions (mm)

--	--	--

2.3.7 - 14/03/2012 (Build 345)

Technical Data

C80 W



AQUAFIX BELGIUM BVBA
Tel. 013 66 83 03, WWW.AQUAFIX.BE



AQUAFIX MILIEU B.V.
Tel. 0297 26 29 29, WWW.AQUAFIX.NL

Operating data					
Flow	0 m ³ /h	m ³ /h	Head	0	m
Shaft power P2		kW	Geodetic head	0	m
Pump efficiency	s	%	Required pump NPSH		m
Pumpe type	Single head pump		No. of pumps	1	
Fluid	Water, clean		Temperature	20 °C	
Density	998.3	kg/m ³	Kin. viscosity	1.005	mm ² /s

Pump					
Pump Code	C80 W		Speed	2900	rpm
Suction port			Head	Max.	4.0 m
Discharge port	R ¾" AG			Min.	0.0 m
Impeller type	Multi vane impeller		Flow	Max.	3.0 m ³ /h
Solid size	1	mm	Pump efficiency max.	0 %	
Impeller Ø	0	mm	Required rated power max. P2	0.0 kW	

Motor					
Motor version	Submersible motor		Insulation class	B	
Motor name	AM 0,09/2 W		Degree of protection	IP 68	
Frequency	50	Hz	Temperature class		
Rated power P1	0.09	kW			
Rated power P2	0.05	kW	Explosion protection		
Rated speed	2900	rpm	Efficiency at % rated power	100%	55 %
Rated voltage	230	V 1~		75%	%
Rated current	0.8	A		50%	%
Starting current, direct starting	0.0	A	cos phi at % rated power	100%	0.99
Starting current, star-delta	0.	A		75%	
Starting mode	Directly		50%		
Power cable	3G0,75		Control cable		
Type of power cable	H05RN-F		Type of control cable		
Cable length	10 m		Service factor	1.15	
Shaft seal					
Bearing	Lower Bearing	Deep Groove Ball Bearing			
	Upper Bearing	Deep Groove Ball Bearing			
Remarks	s				

Materials / Weight			
Suction strainer	Wear resistant synthetic mat	Bolts	Stainless steel
Impeller	Glass-fibre, reinforced synth	Elastomeres	Nitrile Rubber
Motor housing	Stainless steel		
Motor casing	Wear resistant synthetic mat		
Motor shaft	Stainless steel		
Weight aggregat	2.5 kg		

Project	Project no.:	Created by:	Page: 4
---------	--------------	-------------	------------