

Technical Information

MX1330-T72



AQUAFIX BELGIUM BVBA
Tel. 013 66 83 03, WWW.AQUAFIX.BE



AQUAFIX MILIEU B.V.
Tel. 0297 26 29 29, WWW.AQUAFIX.NL

Operating data	
Flow	0 m ³ /h
Head	0 m
Shaft power P2	
Pump efficiency	s %
Required pump NPSH	
Pumpe type	Single head pump
No. of pumps	1
Fluid	Water, clean

Pump	
Pump Code	MX1330-T72
Impeller	Single channel impeller
Impeller size	148 mm
Solid size	80 mm
Discharge port	DN80
Suction port	DN100

Motor	
Rated voltage	400 V
Frequency	50 Hz Hz
Rated power P2	9.5 kW
Rated speed	2900 rpm
Number of poles	2
Efficiency	86 % %
Rated current	18.8 A
Degree of protection	IP 68

Materials	
Motor housing	Grey cast iron EN-GJL-250
Impeller	Grey cast iron EN-GJL-250
Pump housing	Grey cast iron EN-GJL-250
Wear ring	Bronze
Motor shaft	Stainless steel 1.4104
Bolts	Stainless steel
Elastomeres	Nitrile Rubber
Mechanical seal on motor side	SiC / SiC
Mechanical seal on medium side	SiC / SiC
Lower Bearing	Double row angular ball bearing
Upper Bearing	Deep Groove Ball Bearing

Testnorm: P2>10kW, ISO9906
P2<10kW, ISO9906

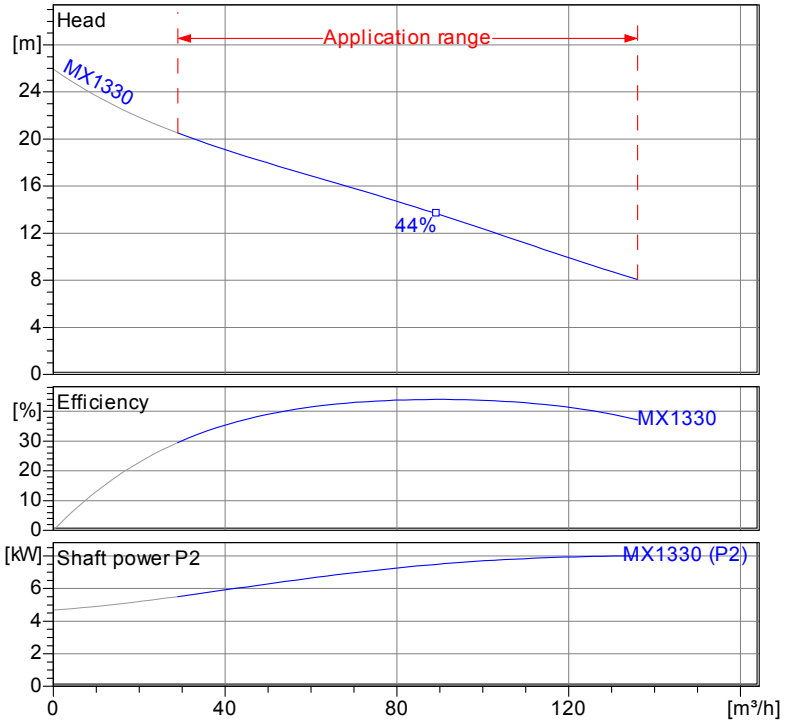

Wet well installation with coupling kit (T)
Dimensions in mm,

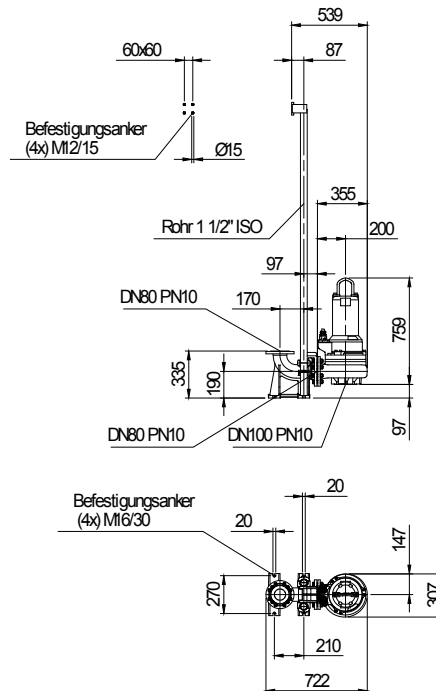

Table Dimensions (mm)

2.3.7 - 14/03/2012 (Build 345)

Project	Project no.:	Created by:	Page: 1
---------	--------------	-------------	------------

Performance Curve

MX1330-T72



AQUAFIX BELGIUM BVBA
Tel. 013 66 83 03, WWW.AQUAFIX.BE



AQUAFIX MILIEU B.V.
Tel. 0297 26 29 29, WWW.AQUAFIX.NL

Impeller						
Impeller type: Single channel impeller	Solid size 80 mm	Ø:	Max. Ø: 206 mm	Min. Ø: 148 mm	Sel. Ø: 148 mm	

Operating data					
Speed: 2900 rpm	Frequency: 50 Hz	Duty point: Q = 0 m³/h	H = 0 m	Shaft power P2:	Discharge port: DN80

Power data referred to:
Water, clean [100%]; 20°C; 998.3kg/m³; 1.005mm²/s

Testnorm: **P2>10kW, ISO9906**
P2<10kW, ISO9906

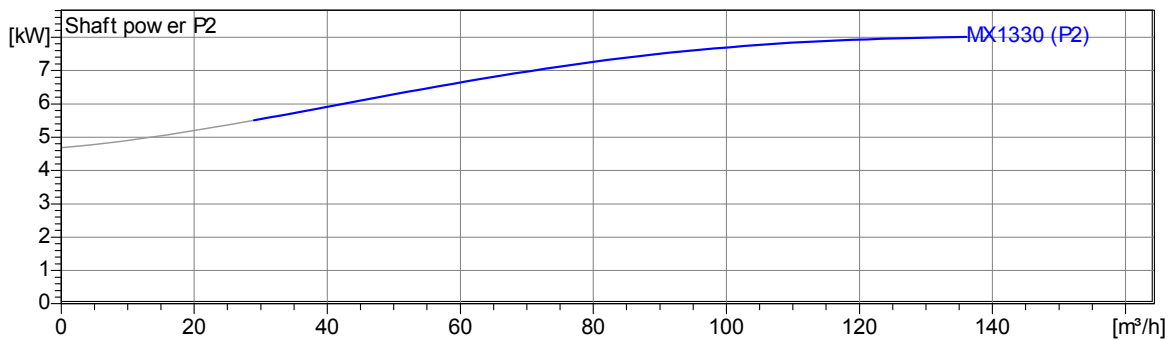
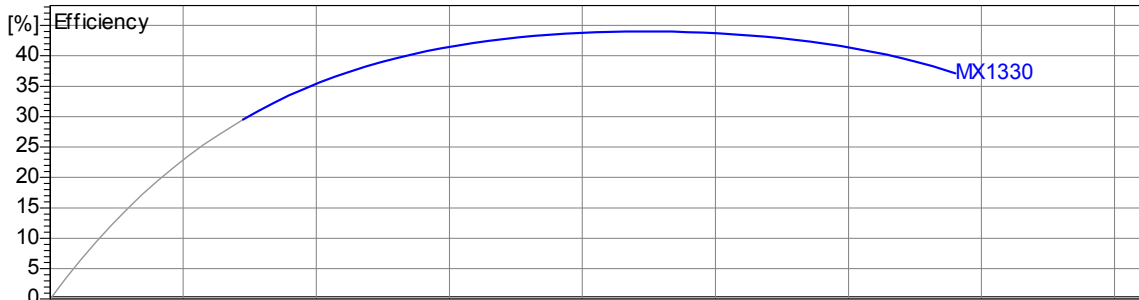
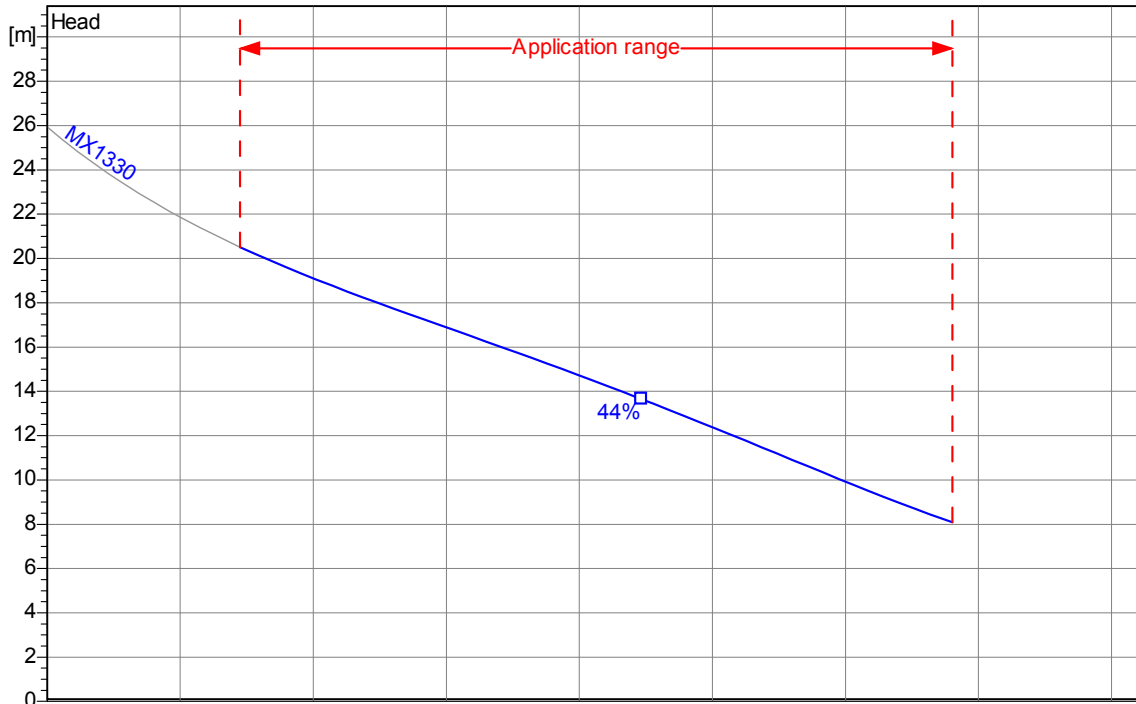

2.3.7 - 14/03/2012 (Build 345)

Project	Project no.:	Created by:	Page: 2
---------	--------------	-------------	-------------------

Dimensions

MX1330-T72



AQUAFIX BELGIUM BVBA
Tel. 013 66 83 03, WWW.AQUAFIX.BE



AQUAFIX MILIEU B.V.
Tel. 0297 26 29 29, WWW.AQUAFIX.NL

Wet well installation with coupling kit (T)
Dimensions in mm, le

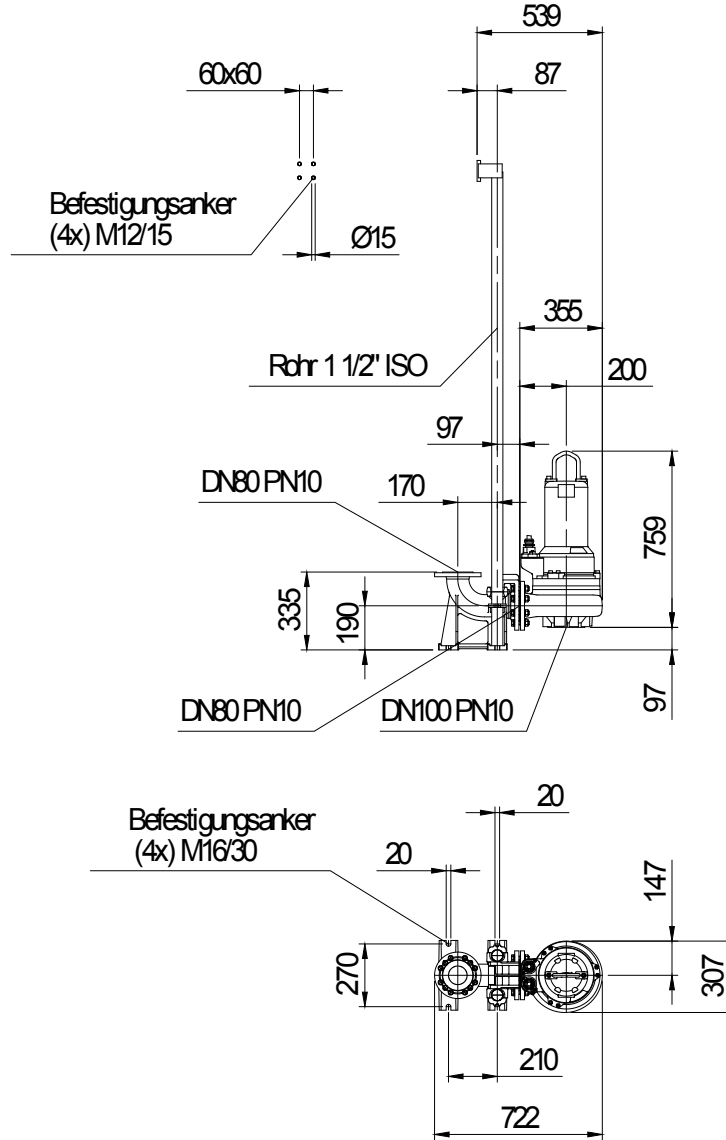

Table Dimensions (mm)

--	--	--

2.3.7 - 14/03/2012 (Build 345)

Project	Project no.:	Created by:	Page: 3
---------	--------------	-------------	------------

Technical Data

MX1330-T72



AQUAFIX BELGIUM BVBA
Tel. 013 66 83 03, WWW.AQUAFIX.BE



AQUAFIX MILIEU B.V.
Tel. 0297 26 29 29, WWW.AQUAFIX.NL

Operating data					
Flow	0 m ³ /h	m ³ /h	Head	0	m
Shaft power P2		kW	Geodetic head	0	m
Pump efficiency	s	%	Required pump NPSH		m
Pumpe type	Single head pump		No. of pumps	1	
Fluid	Water, clean		Temperature	20 °C	
Density	998.3	kg/m ³	Kin. viscosity	1.005	mm ² /s

Pump					
Pump Code	MX1330-T72		Speed	2900	rpm
Suction port	DN100		Head	Max.	20.5 m
Discharge port	DN80			Min.	8.1 m
Impeller type	Single channel impeller		Flow	Max.	136.1 m ³ /h
Solid size	80	mm	Pump efficiency max.	44	%
Impeller Ø	148	mm	Required rated power max. P2	8.0	kW

Motor					
Motor version	Submersible motor		Insulation class	H	
Motor name	AM 173.11/2 T		Degree of protection	IP 68	
Frequency	50	Hz	Temperature class	T4	
Rated power P1	11.0	kW			
Rated power P2	9.5	kW	Explosion protection		
Rated speed	2900	rpm	Efficiency at % rated power	100%	86 %
Rated voltage	400	V 3~		75%	87 %
Rated current	18.8	A		50%	87 %
Starting current, direct starting	112.8	A	cos phi at % rated power	100%	0.89
Starting current, star-delta	37.6	A		75%	0.84
Starting mode	Star-delta			50%	0,71
Power cable	10G1.5		Control cable	-	
Type of power cable	H07RN-F		Type of control cable		
Cable length	10 m		Service factor	1.15	
Shaft seal	Mechanical seal on motor side		SiC / SiC		
	Mechanical seal on medium side		SiC / SiC		
Bearing	Lower Bearing		Double row angular ball bearing		
	Upper Bearing		Deep Groove Ball Bearing		
Remarks	s				

Materials / Weight			
Motor housing	Grey cast iron EN-GJL-250	Bolts	Stainless steel
Pump housing	Grey cast iron EN-GJL-250	Elastomeres	Nitrile Rubber
Impeller	Grey cast iron EN-GJL-250		
Wear ring	Bronze		
Motor shaft	Stainless steel 1.4104		
Weight aggregat	On demand kg		

Project	Project no.:	Created by:	Page: 4
---------	--------------	-------------	------------

2.3.7 - 14/03/2012 (Build 345)